

# Product data sheet

## Characteristics

# 9070TF500D23

Transformer, Type TF, industrial control, 500 VA, 120/240 VAC primary / 24 VAC secondary, 1 phase, 50/60 Hz, 115 °C rise



Product availability: Non-Stock - Not normally stocked in distribution facility

Price\*: 522.00 USD



### Ordering and shipping details

Category	16207 - 9070 TF (NOT T) MTO
Discount Schedule	CP8
GTIN	00785901907145
Nbr. of units in pkg.	1
Package weight(Lbs)	12.10 Lb(US) (5.489 kg)
Returnability	No
Country of origin	US

### Packing Units

Unit Type of Package 1	PCE
Package 1 Height	6.00 In (15.24 cm)
Package 1 width	7.50 In (19.05 cm)
Package 1 Length	6.50 In (16.51 cm)

### Offer Sustainability

Sustainable offer status	Green Premium product
California proposition 65	WARNING: This product can expose you to chemicals including: Phenyl Glycidyl Ether, which is known to the State of California to cause cancer and birth defects or other reproductive harm. For more information go to <a href="http://www.P65Warnings.ca.gov">www.P65Warnings.ca.gov</a>
REACH Regulation	<a href="#">REACH Declaration</a>
EU RoHS Directive	Compliant <a href="#">EU RoHS Declaration</a>
Mercury free	Yes
RoHS exemption information	<a href="#">Yes</a>
China RoHS Regulation	<a href="#">China RoHS Declaration</a>
Environmental Disclosure	<a href="#">Product Environmental Profile</a>
PVC free	Yes

Contractual warranty

---

Warranty	18 months
----------	-----------

---

Approximate Dimensions

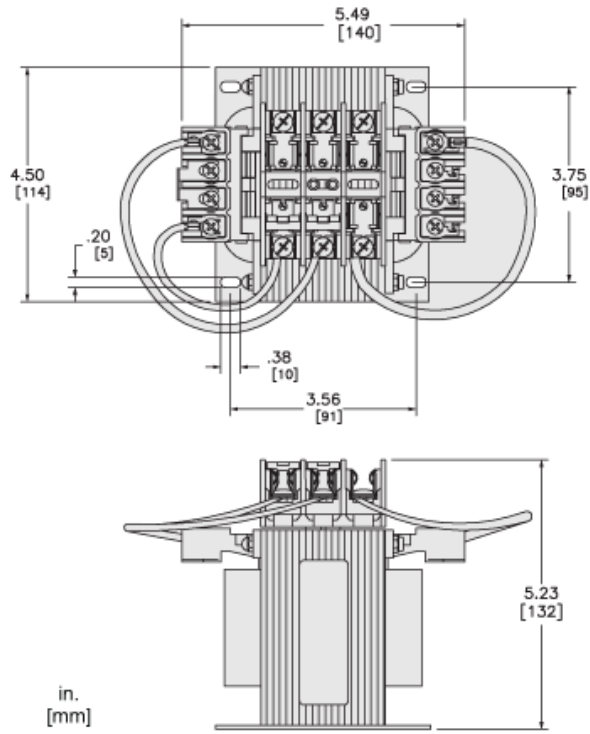

Product Life Status : Commercialised